

Kledingkast Space 3-deurs - wit 175,4x115,8x49,5 cm

Kledingkast Space 3-deurs - wit
Armoire Space 3 portes - blanc



Artikelnummer: | numéro d'article: 12402885



tvilum

12402bb5 - Kleedingskast Space 3D

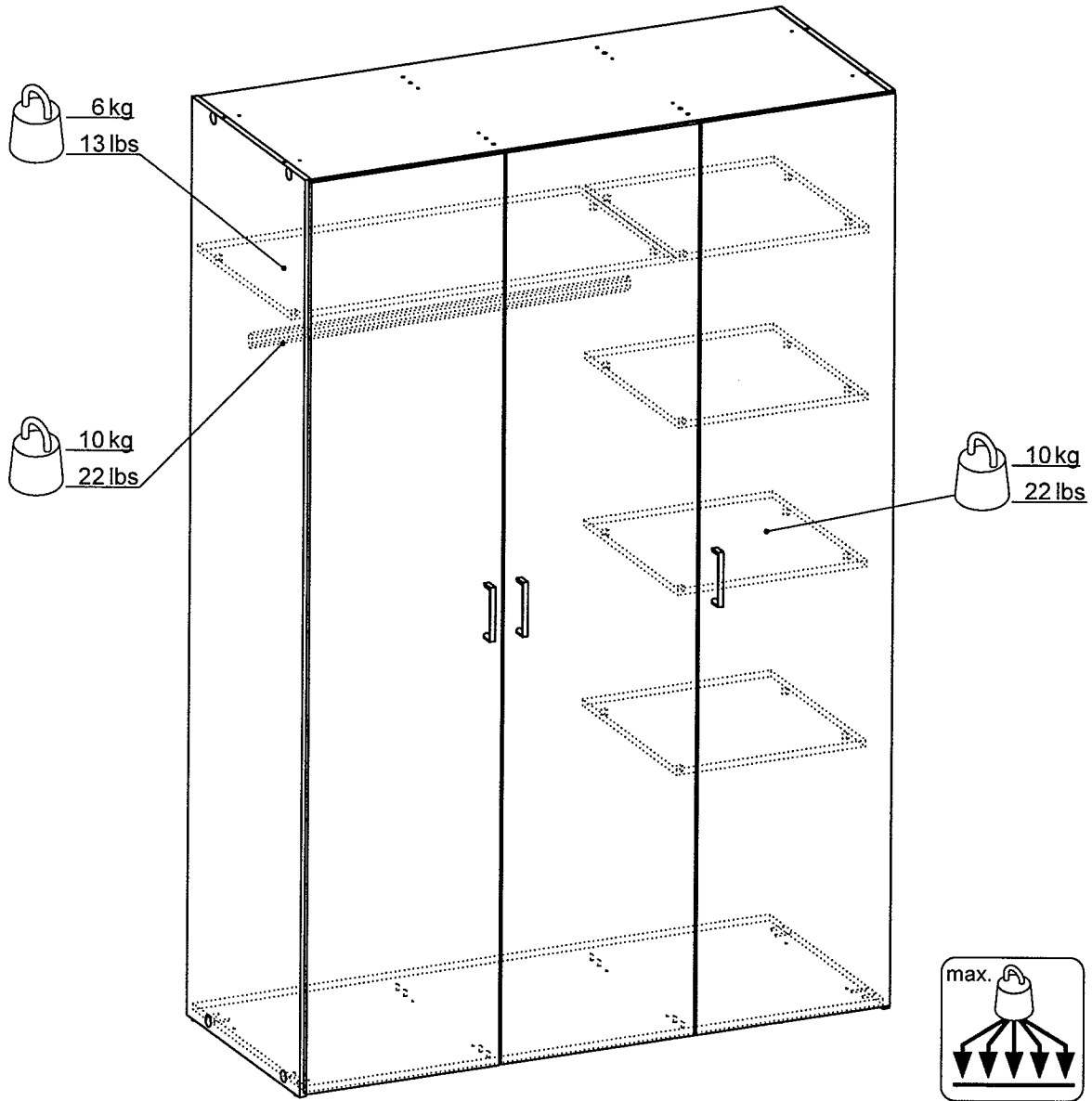

70419

A

2346152/00

BEHANDELD 25 JAN. 2016

www.tvilum.com

<p><input checked="" type="checkbox"/> WE CARE Respect for nature and people Read more at www.tvilum.com</p>	<p>THE GLOBAL COMPACT WE SUPPORT</p>
---	--

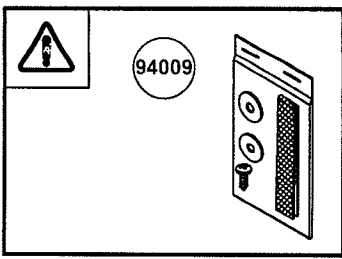

Dansk (da)

VIGTIGT! Skruen som følger med væltesikringen er kun til at fæstne væltesikringen i møbel. Du skal derfor supplere med en skrue eller et beslag som passer til det materiale din væg er lavet af. Hvis du er usikker så kontakt din lokale fagmand.

Norsk (no)

VIKTIG. Legg merke til at skruen som følger med tippebeskyttelsen kun skal brukes for å feste tippebeskyttelsen i møbelet. Kompletter derfor med en skrue eller et fesebeslag tilpasset materialet i veggen din. Er du usikker, ta kontakt med din lokale fagforhandler.

Svenska (sv)

Observera att skruven som medföljer tipskyddet endast är avsedd för att fästa tipskyddet i möbelen. Komplettera därför med en skrue eller ett fastbeslag som passar materialet i din vägg. Är du osäker kontakta din lokala fackhandel.

Suomi (fi)

Huomioi, että turvakiinnikkeen mukana tuleva ruuvi on tarkoitettu ainoastaan kiinnittäkseen turvakiinnikkeen huonekaluun. Täydennä sen vuoksi ruuvilla tai muulla kiinnityksellä joka sopii seinäsi materiaaliin. Ota yhteyttä tavarataloon, jos olet epävarma.

Ierlandis (nl)

BELANGRIJK. De schroeven die bij de wandbevestiging zitten, zijn uitsluitend bedoeld om de wandbevestiging aan het meubel te bevestigen. Completeer de wandbevestiging met een schroef of bevestigingsbeslag dat geschikt is voor het materiaal van de wand. Neem bij twijfel contact op met de ijzerhandel.

Français (fr)

IMPORTANT: Les vis fournies avec le dispositif anti basculement sont à fixer sur le meuble. Pour la fixation au mur, compléter par une vis adaptée au support mural. En cas de doute, contacter un magasin de bricolage.

Polski (pl)

UWAGA! W komplecie z mocowaniami zapobiegającym wywróceniu mebla są śruby, które służą tylko do przytwierdzenia ich do mebla. Rodzaj śrub przytwierdzających je do ściany zależy od rodzaju materiału z jakiego została wykonana (gips, cegła, drewno itd.). Będą więc potrzebne dodatkowe odpowiednie śruby. Jeśli masz wątpliwości co do rodzaju śrub zasięgnij opinii fachowca.

Čeština (cs)

DŮLEŽITĚ. Šroub přibalený k bezpečnostnímu kování je určen pouze k přichycení kování k nábytku. Je nutné, zvolit šroub k přichycení kování ke stěně, který je vhodný vzhledem k typu vaší stěny. V případě, kdy si nejste jisti, jaký šroub použít, žádejte o radu v nejbližším obchodě železářství nebo v obchodě domácích potřeb.

Magyar (hu)

FONTOS. A dőlést megakadályozó tartóhoz kapott csavar kizárólag a tartó bútorhoz történő rögzítéséhez használható. Ezen felül ki kell választania, hogy milyen csavart vagy szelervényt használjon ahhoz a falhoz, ahova a tartókart rögzíteni szeretné. Amennyiben nem biztos benne, hogy milyen csavart kell használnia, lépjen kapcsolatba a helyi vasárbolttal.

Slovenčina (sk)

DŮLEŽITÉ UPOZORNENIE. Skrutka dodávaná spolu s bezpečnostným kováním je určená iba na upevnenie kovania k nábytku, okrem toho budete potrebovať skrutku za prichytenie kovania k stene. Túto si vyberte podľa druhu steny. Ak si nie ste istý, aký, druh skrutky potrebujete, kontaktujte najbližšie železiarstvo.

Slovenščina (sl)

POMEMBNO Priloženi vijak, skupaj z nosilcem za pritržitev proti prevrnitvi, je namenjen izključno pritrževanju nosilca za pritržitev proti prevrnitvi na pohištvo. Poleg tega boste potrebovali tudi ustrezen vijak oz. element za pritrževanje nosilca na vaš tip stene. Če niste prepričani o tem, kakšen vijak je najprimernejši, se obrnite na eno od tehničnih trgovin v vaši bližini.

Hrvatski (hr)

VAŽNO Isporučeni vijak i sigurnosni nosač treba upotrijebiti samo za pričvršćivanje sigurnosnog nosača na namještaj. Uz to, morat ćete odabrati vijak ili spojni element prikladan za pričvršćivanje nosača na odgovarajuću vrstu zida. Ako niste sigurni koju vrstu vijaka trebete upotrijebiti, pitajte u lokalnoj trgovini željezarijom.

Русский (ru)

ВАЖНО. Болт, поставляемый вместе с держателем против опрокидывания, должен использоваться только для крепления данного держателя к мебели. В дополнение к этому необходимо подобрать шуруп или крепление для фиксации держателя на стене в зависимости от ее типа. Если вы не уверены, какой шуруп использовать, обратитесь за консультацией в местный магазин строительных товаров.

Bosanski (bs)

Važno: Vijak priložen uz nosač sa zaštitom od prevrtanja je namijenjen samo za pričvršćivanje nosača na namještaj. Uz to bit će potrebno da odaberete vijak ili

spojni element pogodan za pričvršćivanje nosača na odgovarajuću vrstu zida. Ako niste sigurni koju vrstu vijaka odabrati pitajte u lokalnoj prodavaonici građevinskog materijala.

Srpski (sr)

Važno: Ovaj zavrtanj, koji se isporučuje zajedno sa sigurnosnim nosačem, treba koristiti samo za pričvršćivanje sigurnosnog nosača na nameštaj. Pored toga, treba da izaberete odgovarajući zavrtanj ili spojni element za pričvršćivanje nosača na odgovarajuću vrstu zida. Ako niste sigurni koju vrstu zavrtnja da upotrebite, obratite se lokalnom gvožđaru.

Українська (uk)

Важливо: Болт, який постачається разом з тримачем від перекидання, повинен використовуватися тільки для кріплення цього тримача до меблів. Крім цього, необхідно підібрати шуруп або кріплення для фіксації тримача на стіні, залежно від її типу. Якщо ви не впевнені, який шуруп використовувати, зверніться за консультацією до місцевого магазину будівельних товарів.

Română (ro)

IMPORTANT. Șurubul furnizat împreună cu consola anti-răsturnare va fi utilizat doar pentru fixarea consolei anti-răsturnare pe mobilă. Pe lângă aceasta, va trebui să alegeți un șurub sau montură adecvată pentru fixarea consolei pe tipul de perete din încăperea respectivă. Dacă aveți nelămuriri privind tipul de șurub de utilizat contactați magazinul local de scule și unelte.

Български (bg)

ВАЖНО. Доставкаият винт, заедно с крепежната скоба, се използва единствено за закрепване на крепежната скоба към мебелите. Освен това все още трябва да изберете винт или фитинг, който е подходящ за закрепване на скобата към вида на Вашите стени. Ако не сте сигурни какъв вид винт да използвате, свържете се с местния магазин за инструменти за дома.

Ελληνικά (el)

ΣΗΜΑΝΤΙΚΟ. Η βίδα που παρέχεται μαζί με το αντιανατρεπτικό στηρίγμα πρέπει να χρησιμοποιηθεί μόνο για τη στερέωση του αντιανατρεπτικού στηρίγματος στο έπιπλο. Εκτός από αυτή τη βίδα, θα χρειαστείτε μία βίδα ή εξάρτημα που είναι κατάλληλο για τη στερέωση του στηρίγματος στο είδος του τοίχου που έχετε. Εάν δεν είστε σίγουροι για τον τύπο της βίδας που πρέπει να χρησιμοποιήσετε, επικοινωνήστε με ένα σιδηροπωλείο.

Türkçe (tr)

ÖNEMLİ. Devrilmevi önleyen destek ile birlikte verilen vida, yalnızca devrilmevi önleyen desteği mobilyaya monte etmek için kullanılacaktır. Buna ek olarak, desteği sahip olduğunuz duvar türüne monte etmeniz için uygun bir vida veya bağlantı elemanı seçmeniz de gerekecek. Eğer hangi tür vida kullanacağınızdan emin değilseniz yerel hırdavatçınıza başvurun.

中文 (zh)

重要提示：

随防倒支架同时提供的螺钉只可用于固定家具的防倒支架。此外，您需要根据墙壁类型来选择合适规格的螺钉或配件来固定支架。如果您不确定该使用何种螺钉，请咨询当地五金商店。

English (en)

IMPORTANT: The screw supplied together with the anti-topple bracket is to be used only for fixing the anti-topple bracket to the furniture. In addition to this, you will need to choose a screw or fitting which is suitable for securing the bracket to the kind of walls you have. If you are unsure about what type of screw to use contact your local hardware store.

Deutsch (de)

WICHTIG. Die dem Kippschutz beigelegten Schrauben sind ausschließlich für die Befestigung des Kippschutzes am Möbelstück vorgesehen. Für die Befestigung des Kippschutzes an der Wand benötigen Sie zusätzlich Schrauben oder Beschläge, die zur Beschaffenheit der Wand passen. Falls Sie nicht sicher sind, welche Art von Schrauben geeignet sind, wenden Sie sich bitte an den Fachhandel.

Español (es)

¡IMPORTANTE! El tornillo que viene incluido con el soporte antivuelco está destinado a fijarlo en el mueble. Debes fijar el antivuelco en la pared con un tornil o similar de un tipo acorde con el material de esta. Consulta con tu ferretería.

Italiano (it)

IMPORTANTE. Le viti che vengono fornite insieme al dispositivo antiribaltamento vanno utilizzate soltanto per fissare questo dispositivo al mobile. Scegli quindi le viti o il dispositivo di fissaggio che più si adattano alle pareti di casa tua. In caso di dubbi contatta il tuo ferramenta.

日本語 (ja)

重要 くらつき防止用ブラケットに同梱されているネジは、くらつき防止用ブラケットを家具に取り付けるための専用ネジです。また、ブラケットを取り付けるには、ご使用の壁の種類に応じて、適切なネジまたは取付金具を選ぶ必要があります。使用すべきネジの種類が分からない場合は、お近くの金物店までお問い合わせください。

Português (pt)

MUITO IMPORTANTE. O parafuso fornecido junto com o dispositivo anti-queda deve ser usado unicamente para para fixar o dispositivo anti-queda ao móvel. Deve também escolher um parafuso ou fixação que seja adequada para segurar o dispositivo ao tipo de paredes que tiver. Se não tiver a ceteza de que tipo de parafuso deve usar, deve dirigir-se a uma loja especializada.

Català (Cat)

!!! IMPORTANT !!! El cargol que ve inclòs amb el suport antibolcada està destinat a fixar-lo al moble. Heu de fixar l'antibolcada a la paret amb un cargol similar d'acord al material de la paret, consulti el seu ferreter.

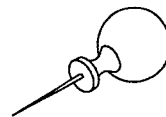
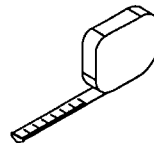
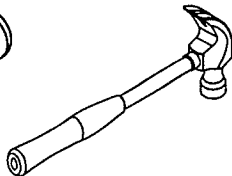
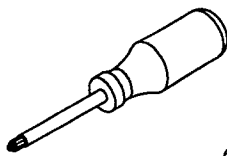
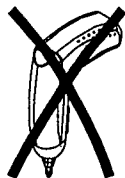
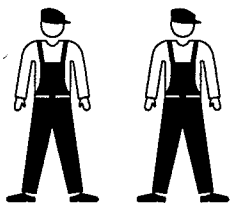

10601
x2

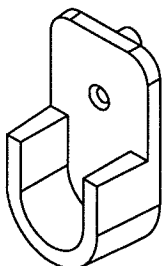

10901
x1

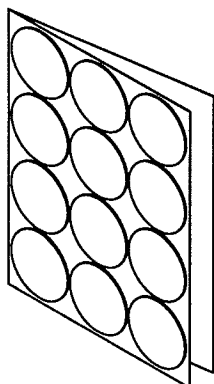

11023
x20

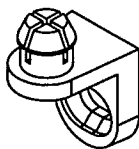

12754
x8

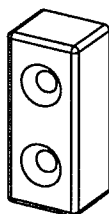

13412
x2

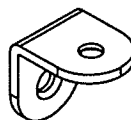

20203
x12



72525
x1

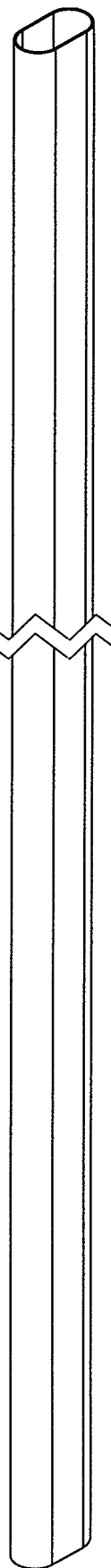

74475
x1



23006
x3

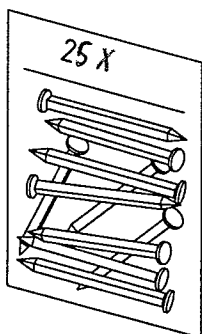

23008
x17



25215
x6



25253
x16



25447
x6



25604
x12

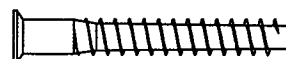
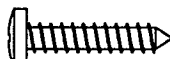
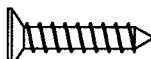
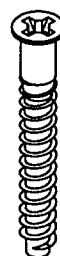

26039
x20



26071
x18



26211
x9



50491
x9

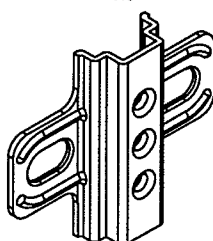

52291
x9

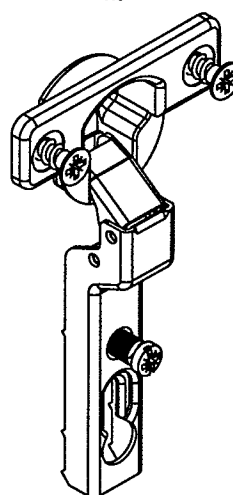

63001
x4



80418
x3

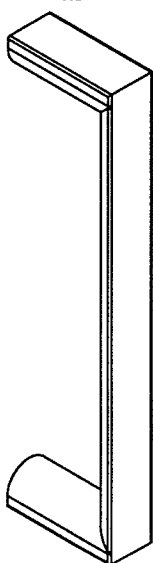

94009
x2

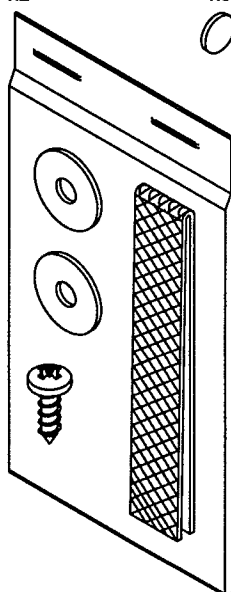

96203
x6



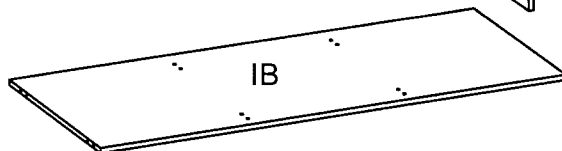
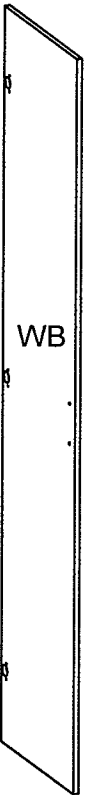
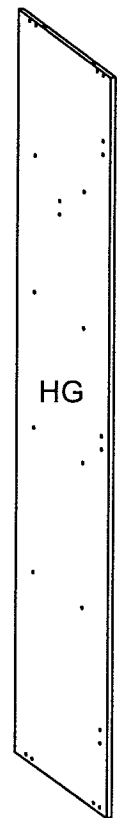
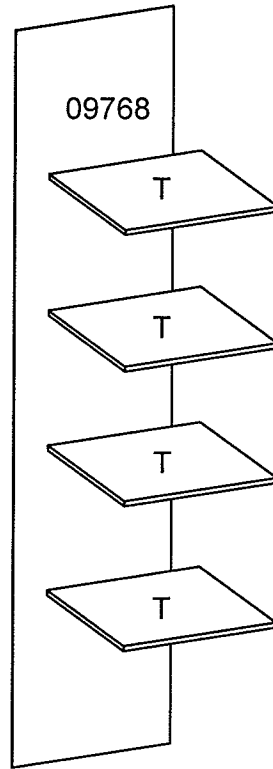
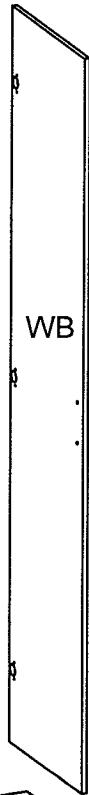
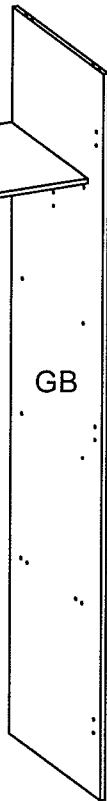
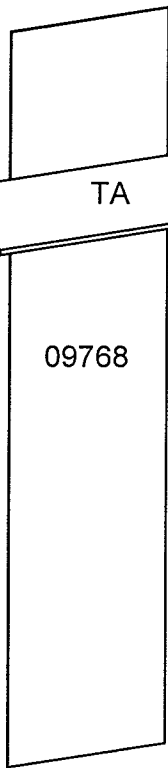
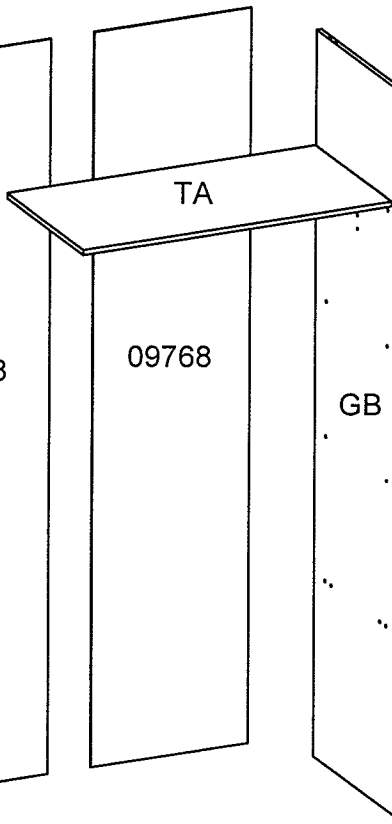
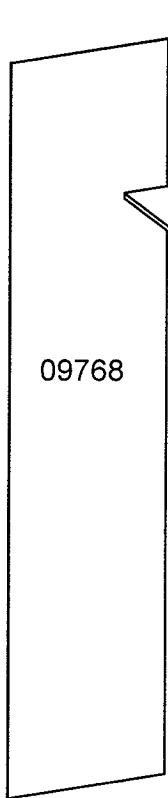
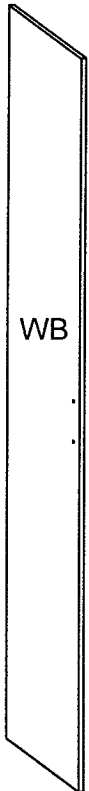
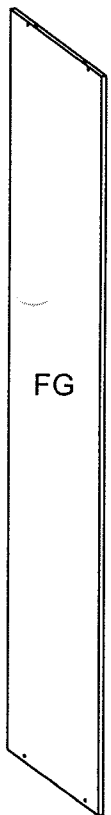
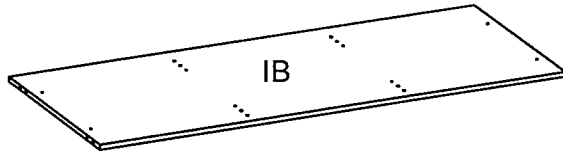
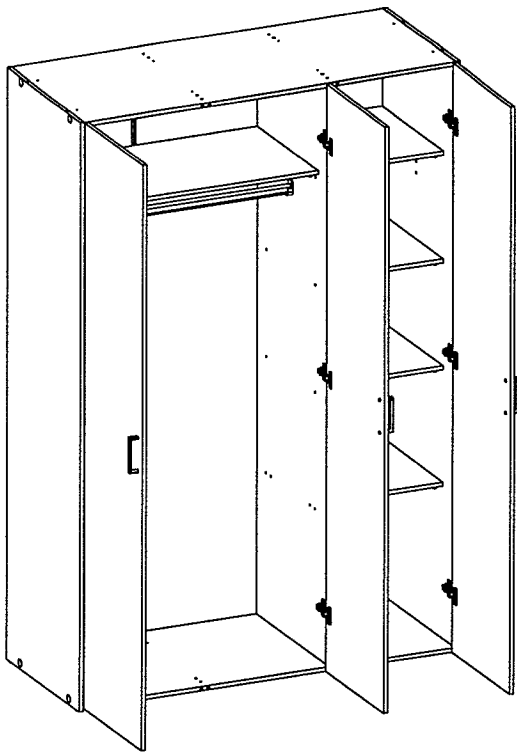

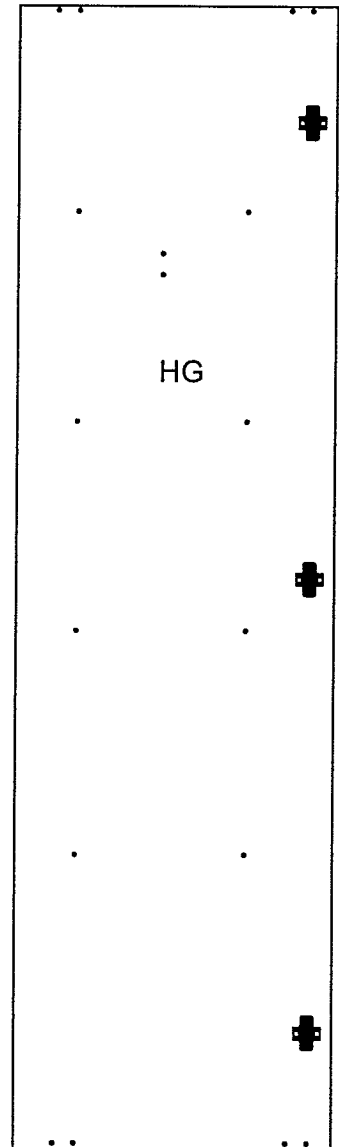
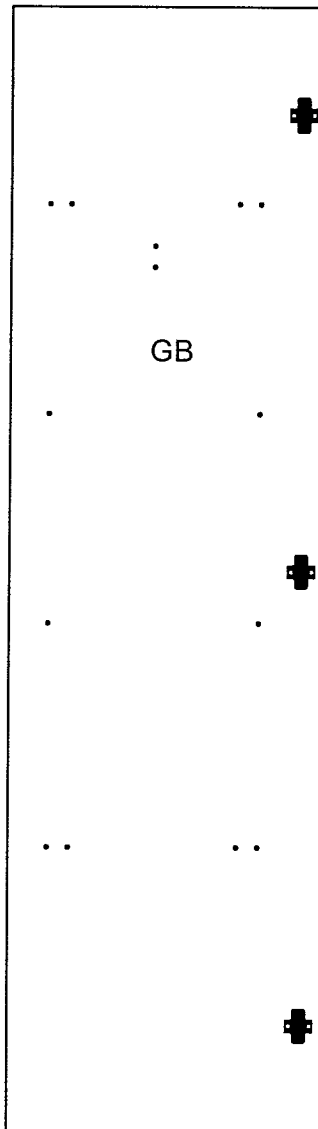
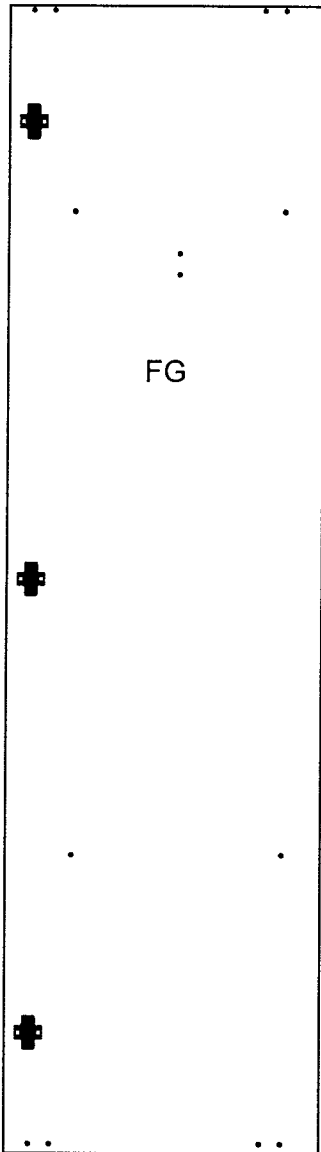
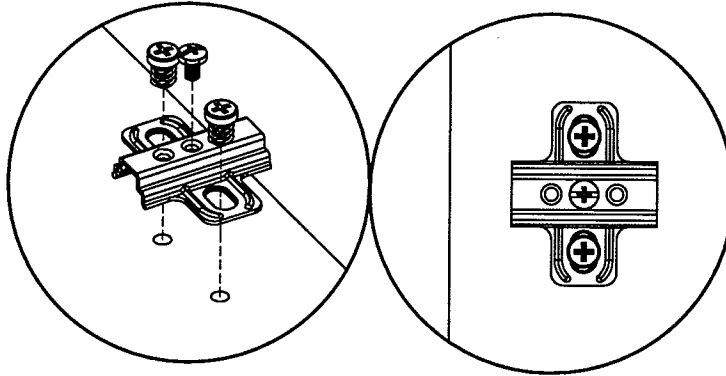
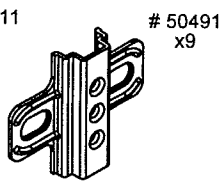
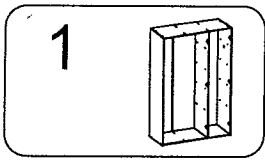

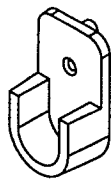
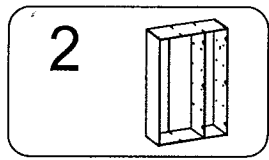

10601
x2

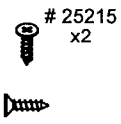

25215
x2

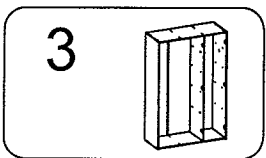
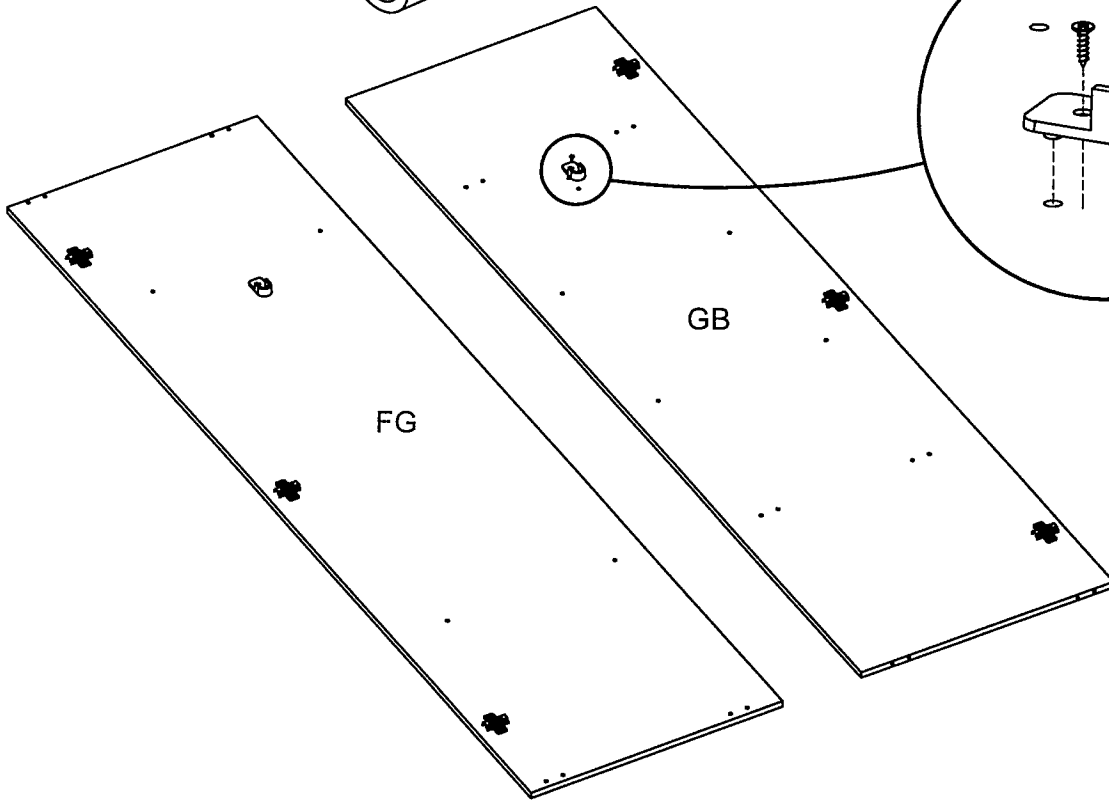

20203
x12

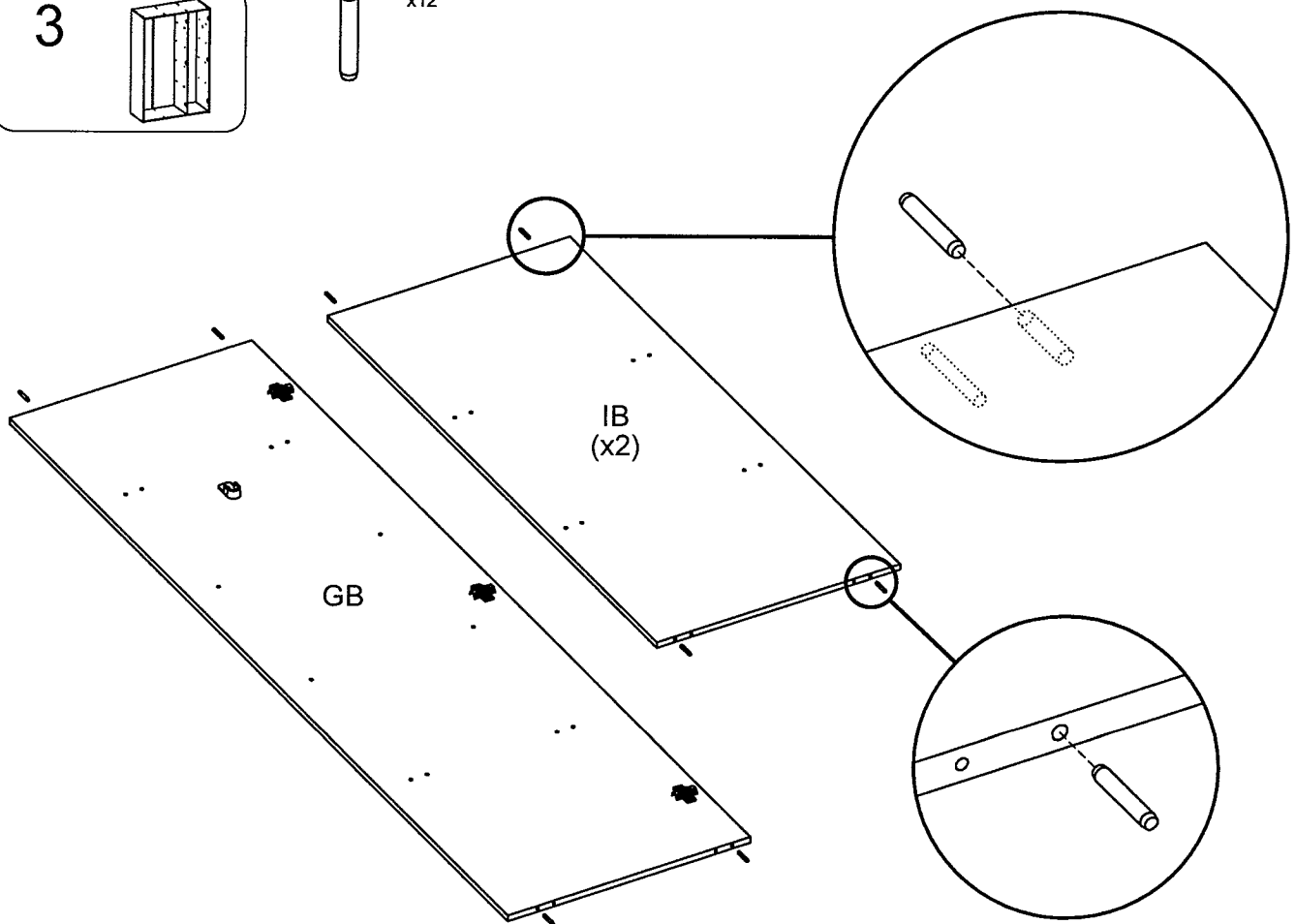

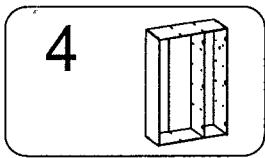

25604
x4

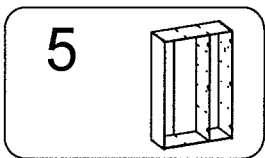
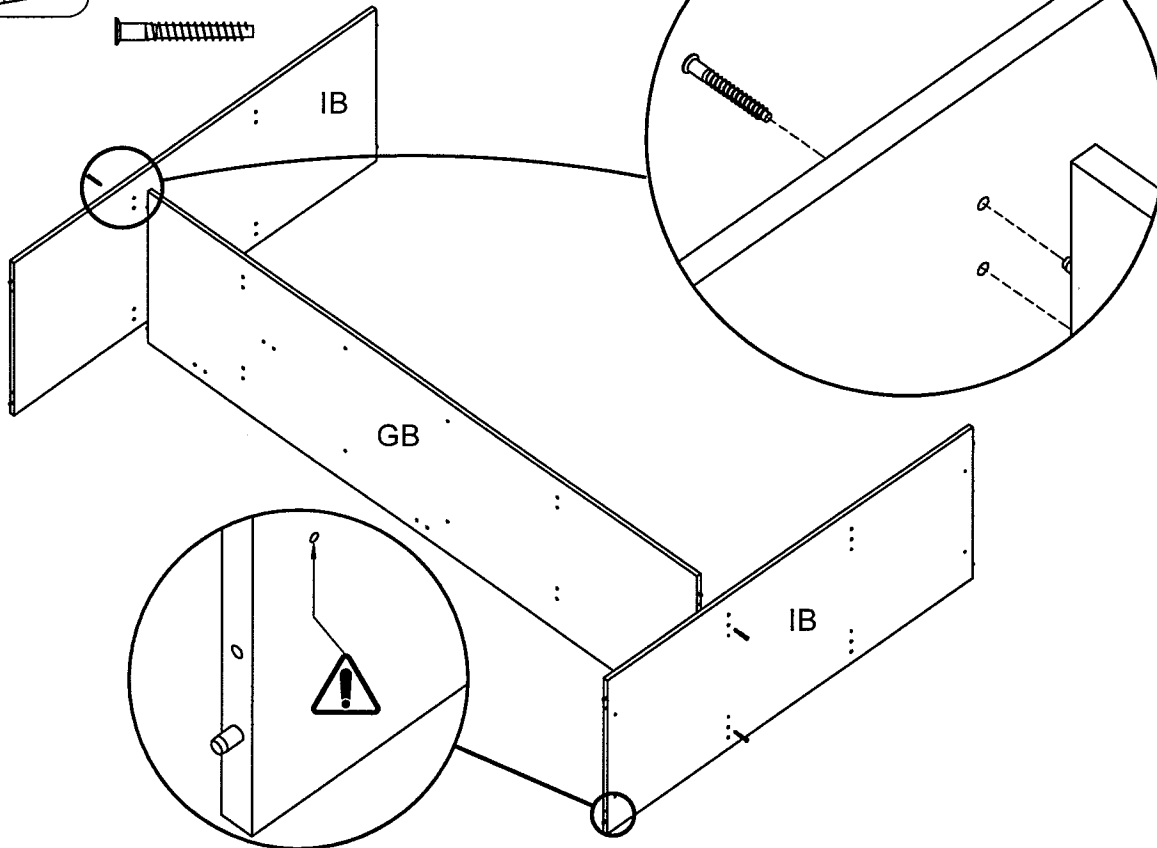
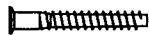

25604
x8

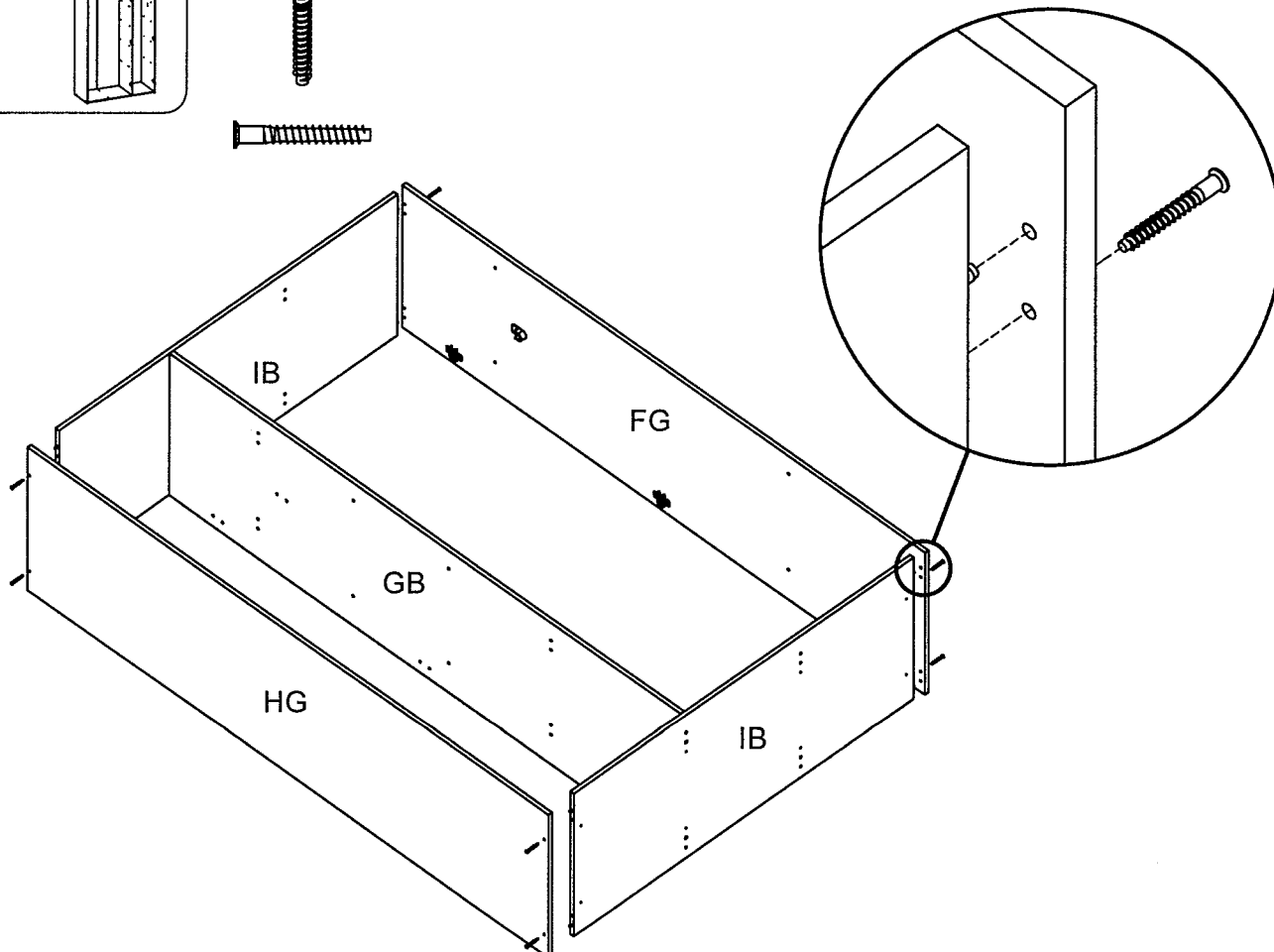
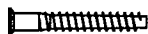

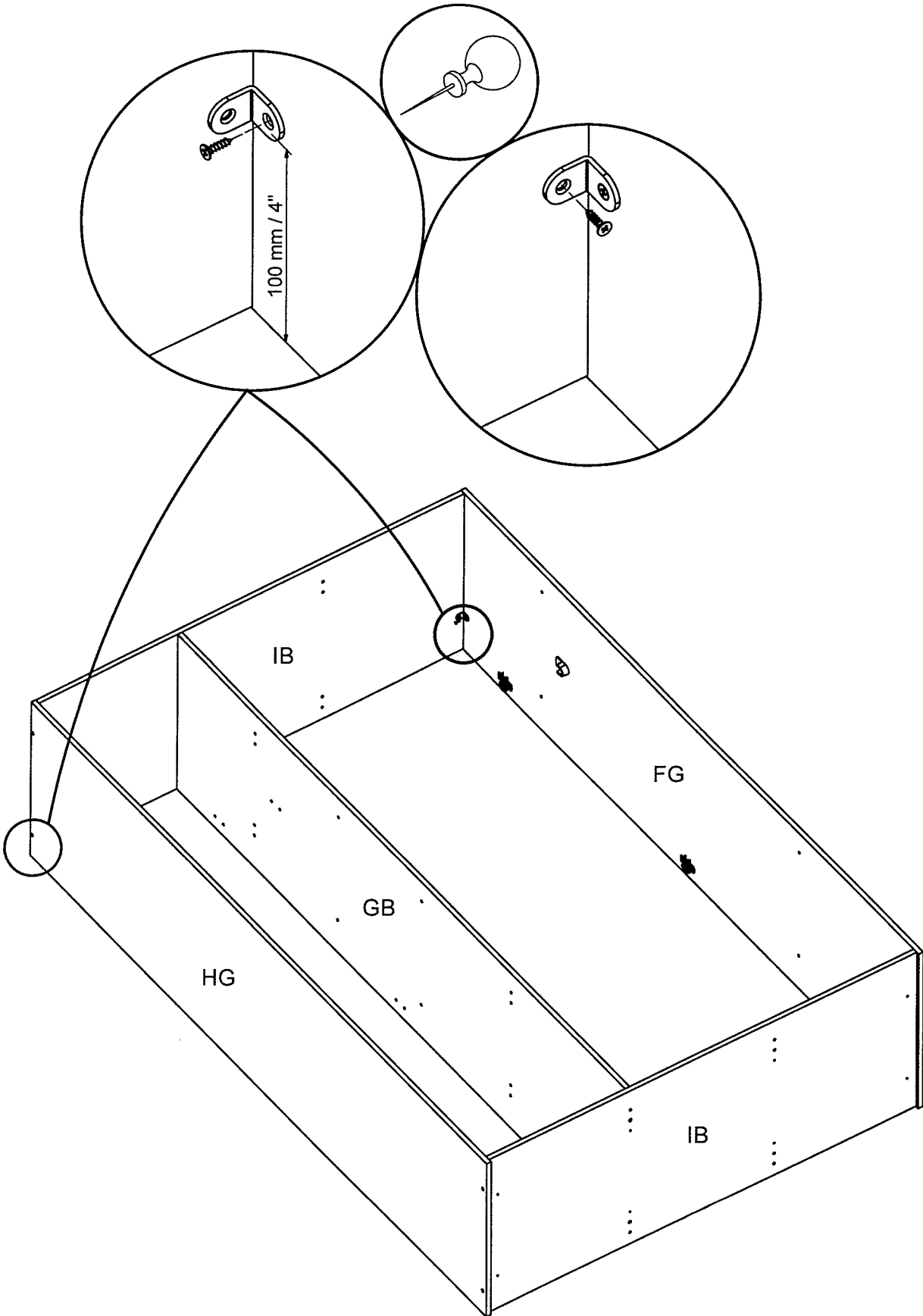
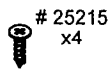
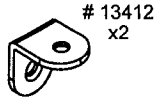
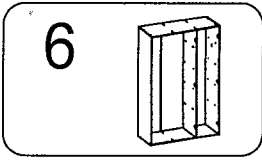

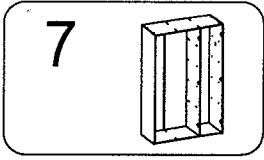

23008
x3

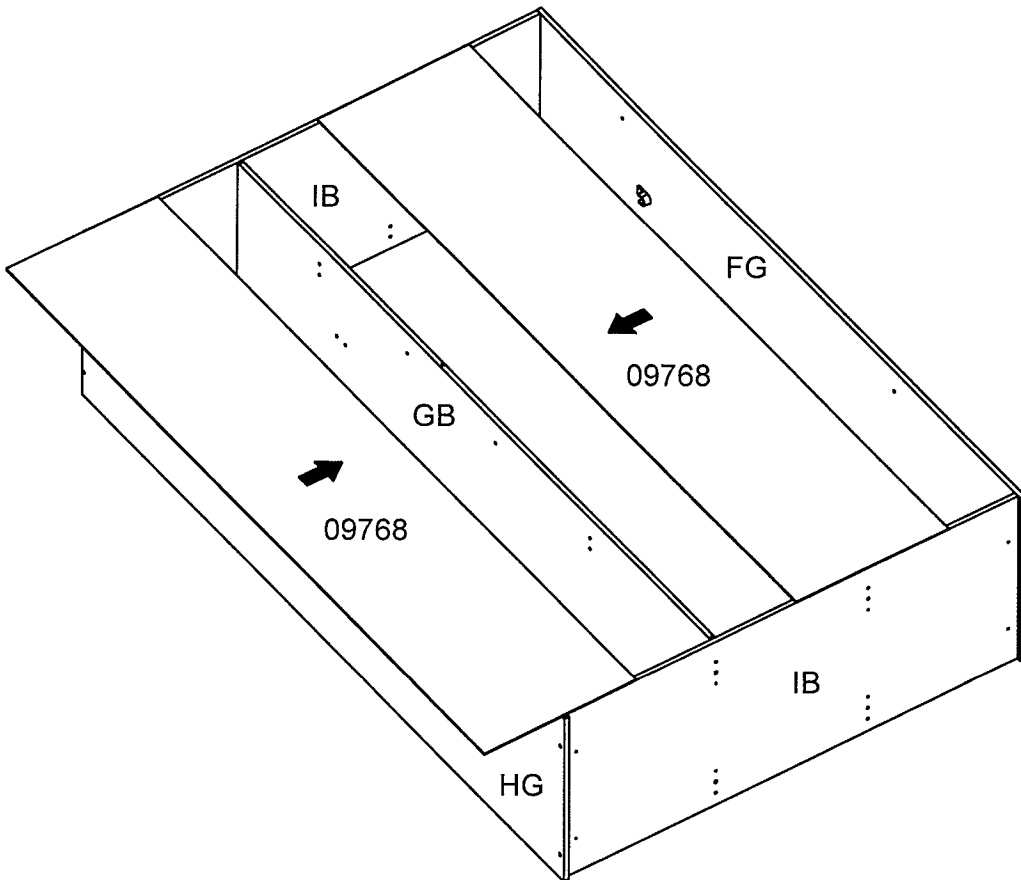
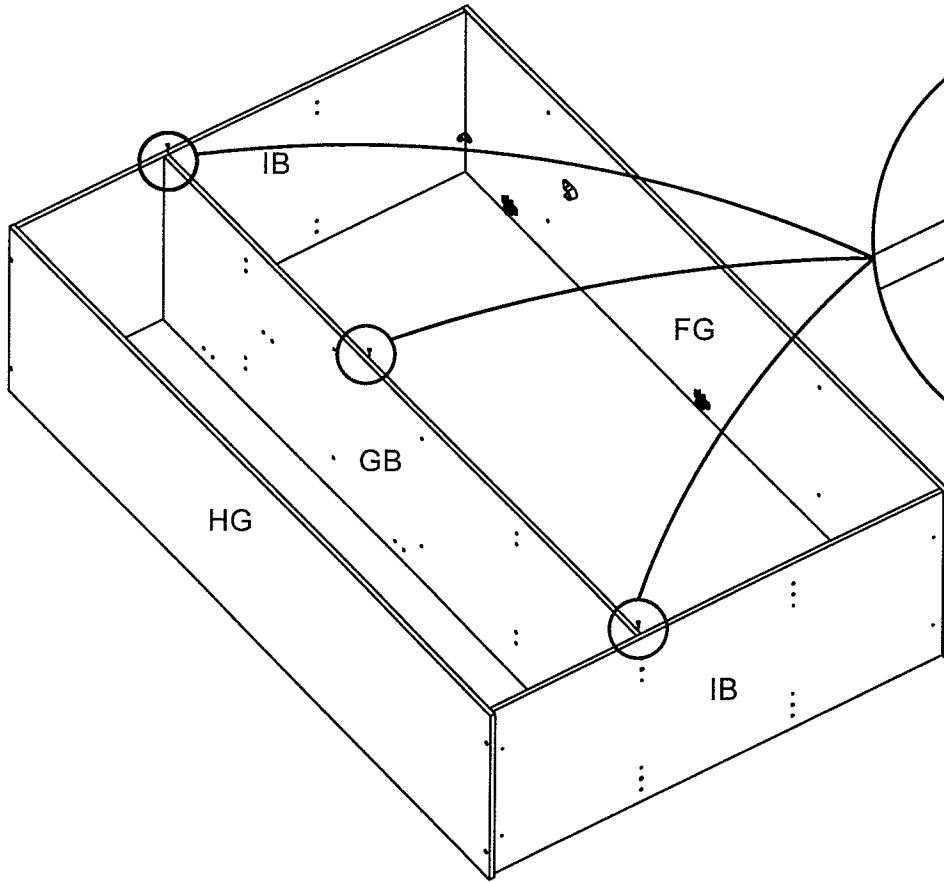

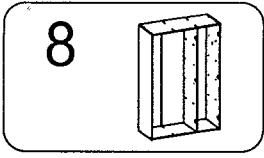

74475
x1

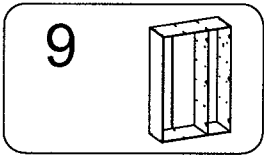
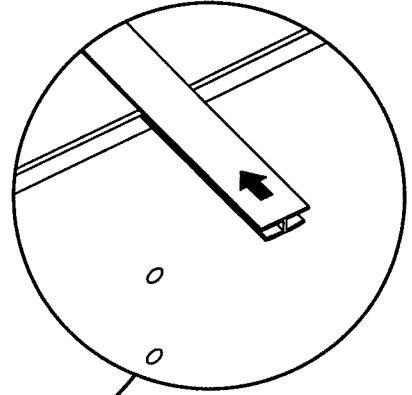
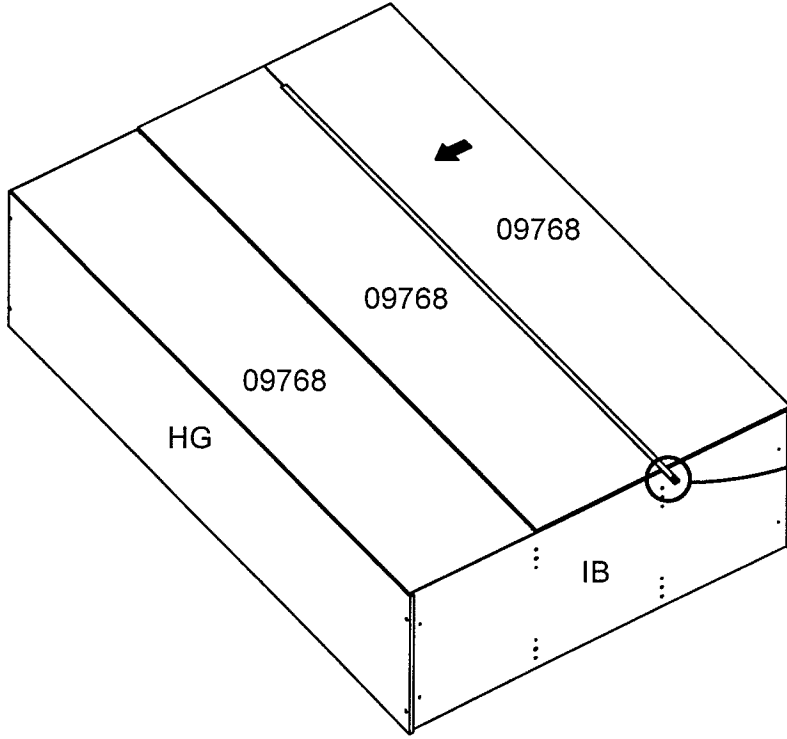
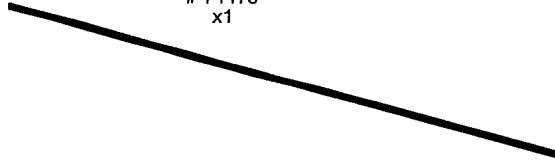

23006
x3

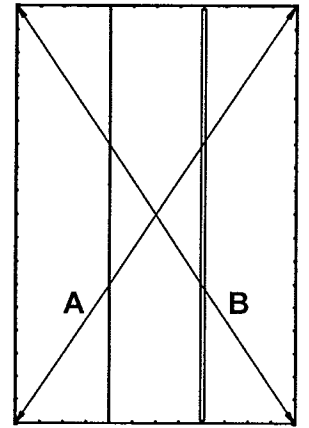
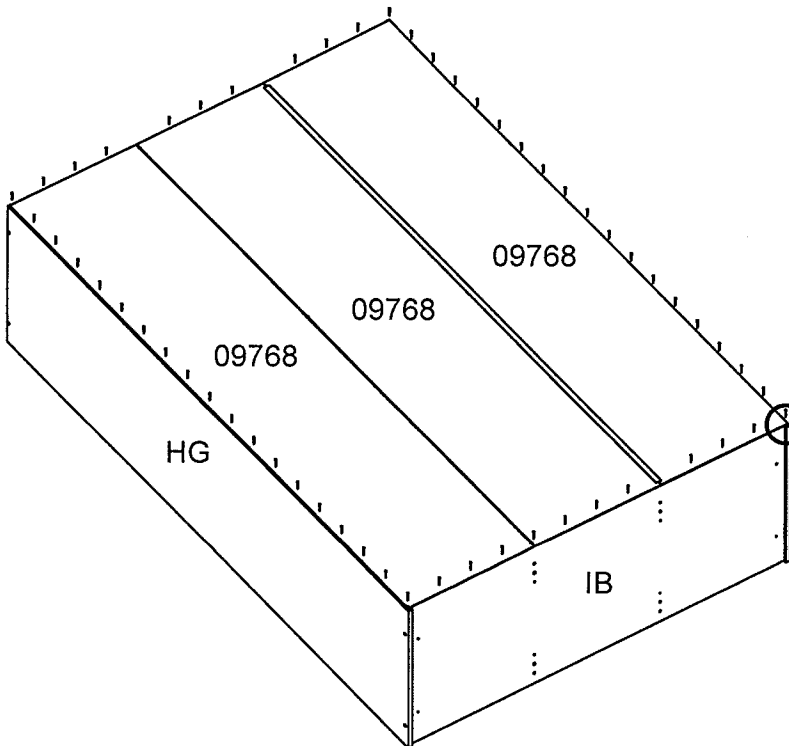
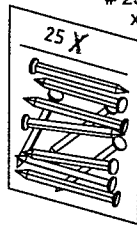

A = B

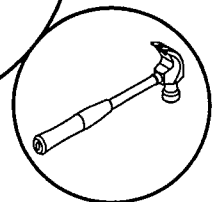
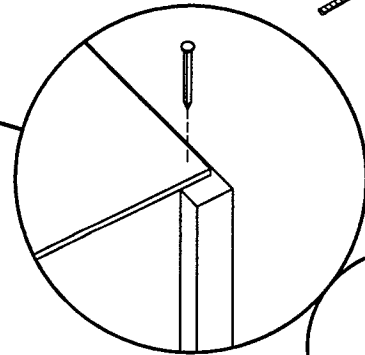

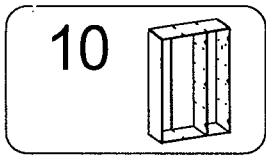

23008
x14

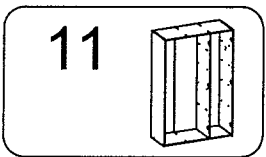
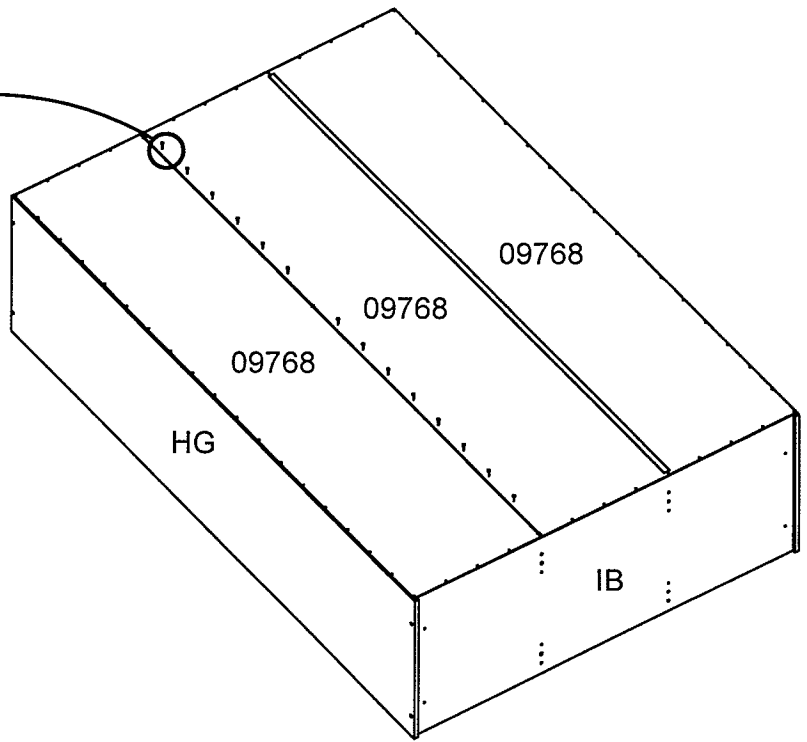
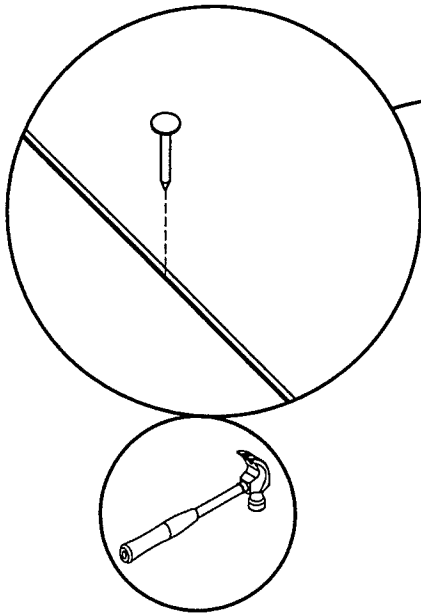

12754
x8

25253
x16

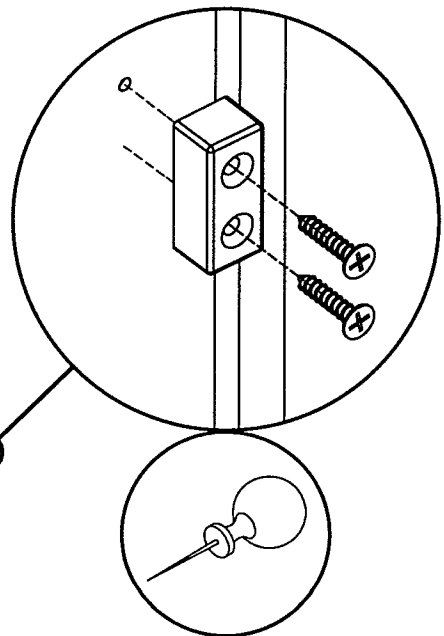
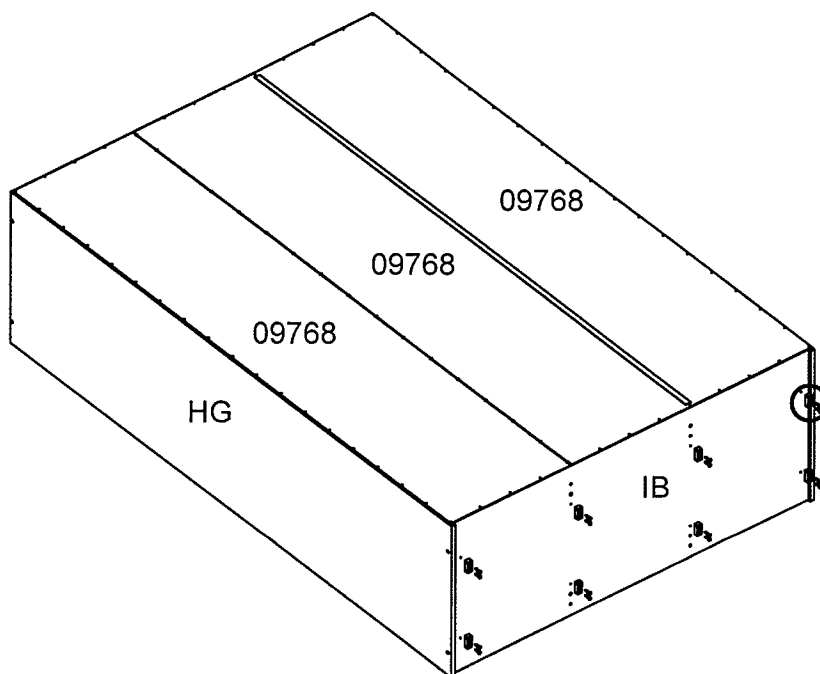

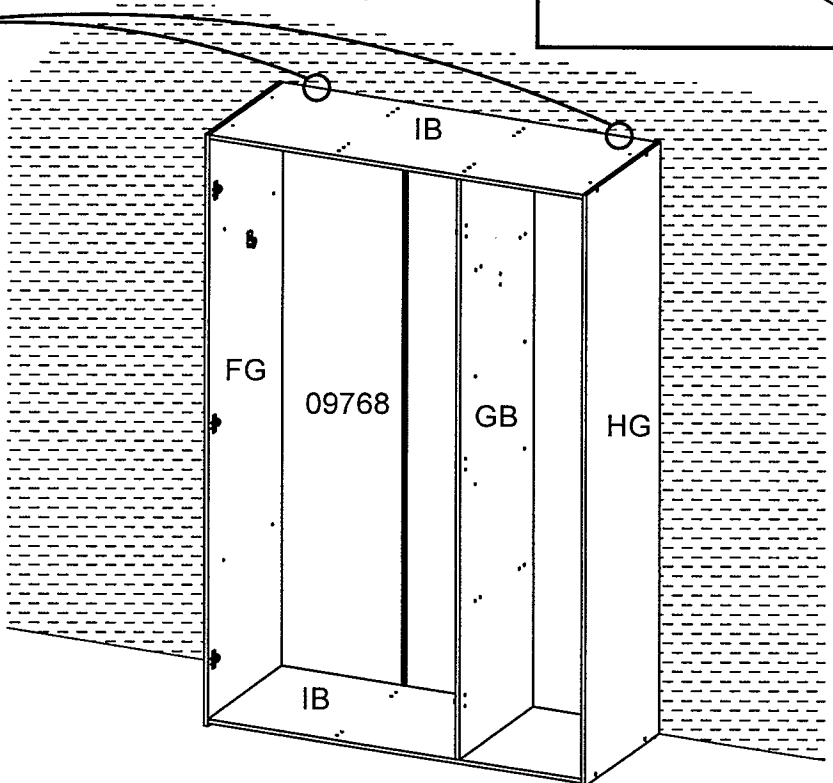
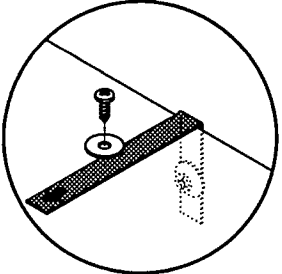
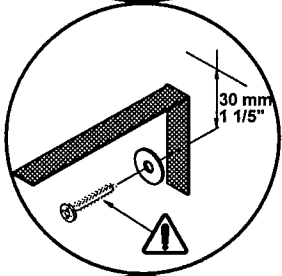
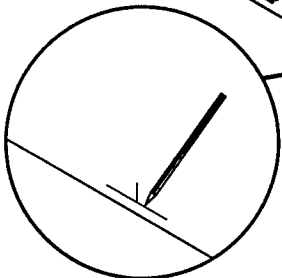
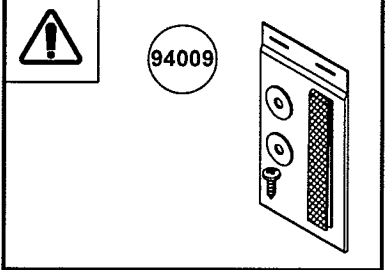
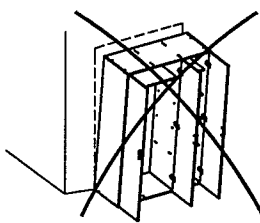
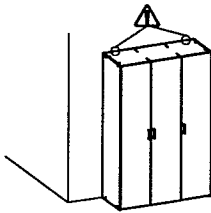
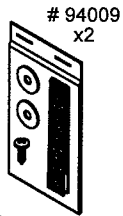
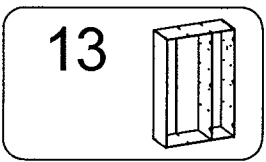
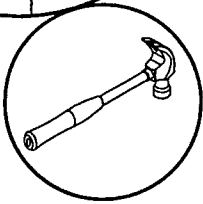
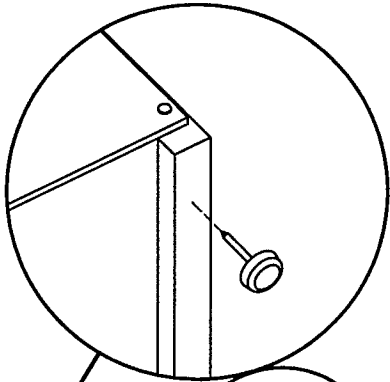
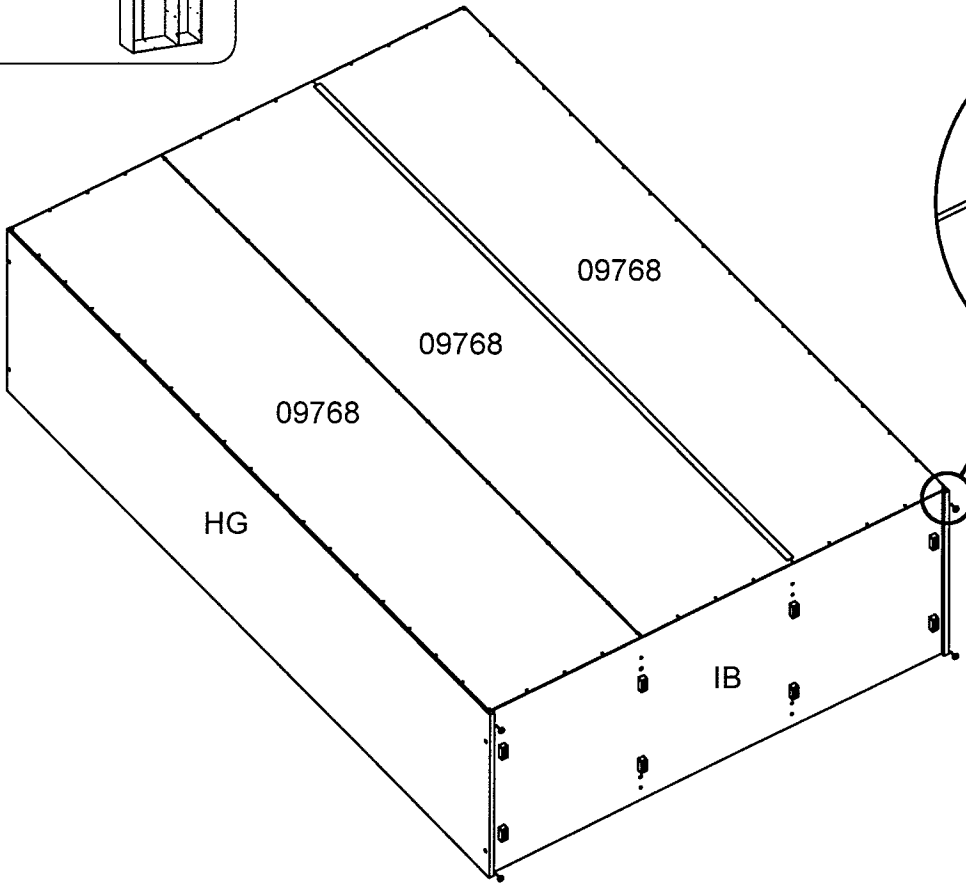
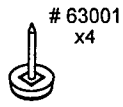
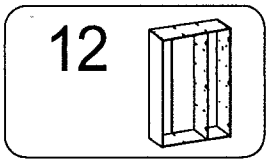

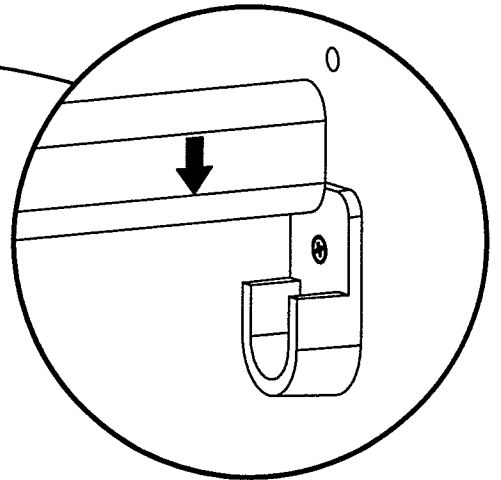
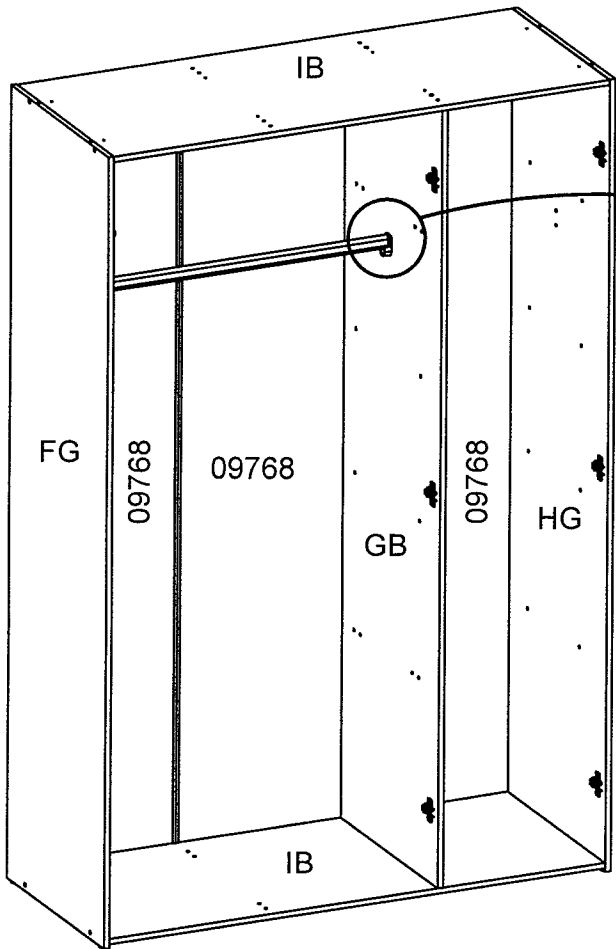
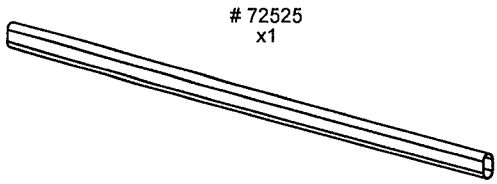
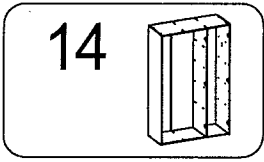

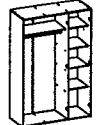
15 

11023
x20

26039
x20

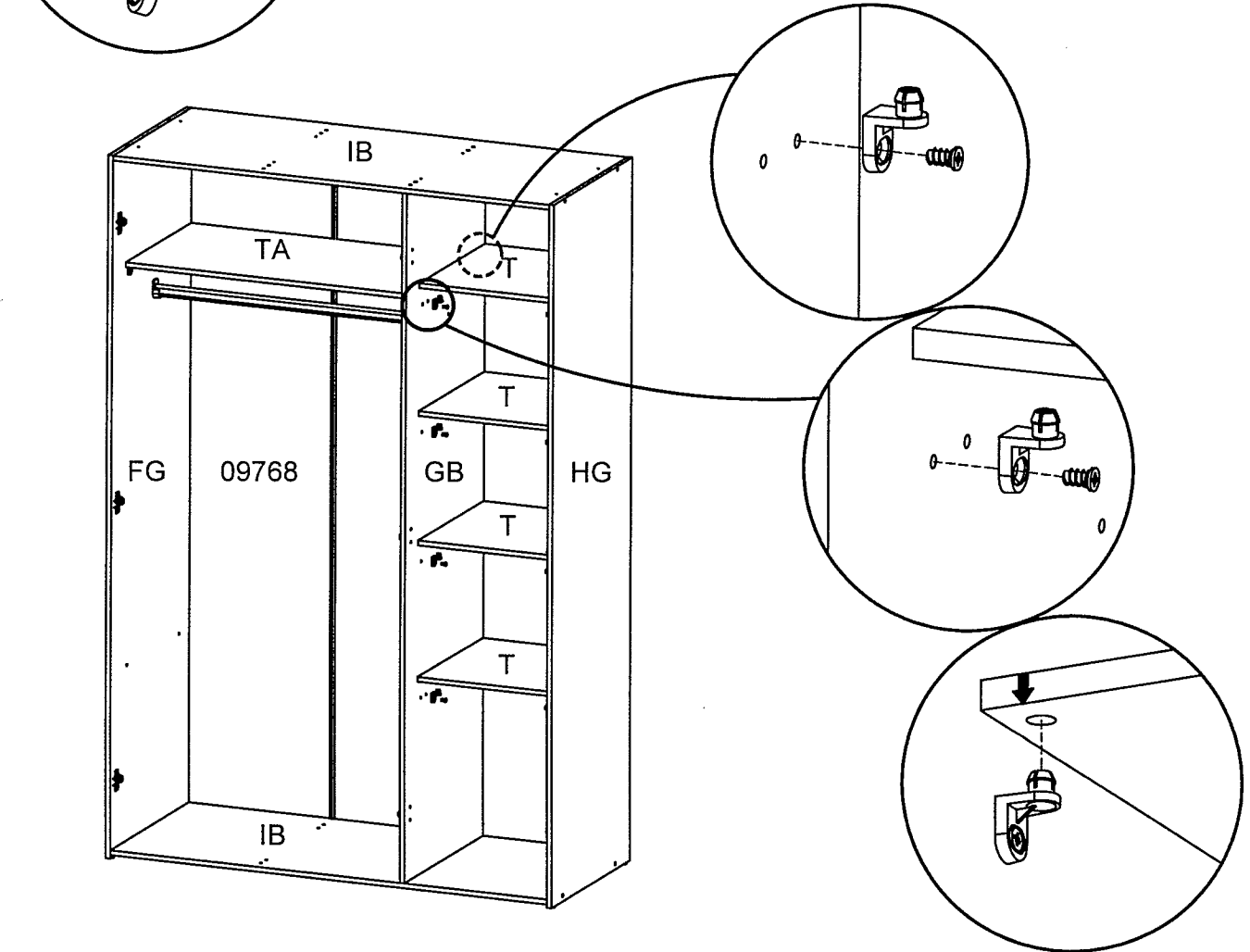
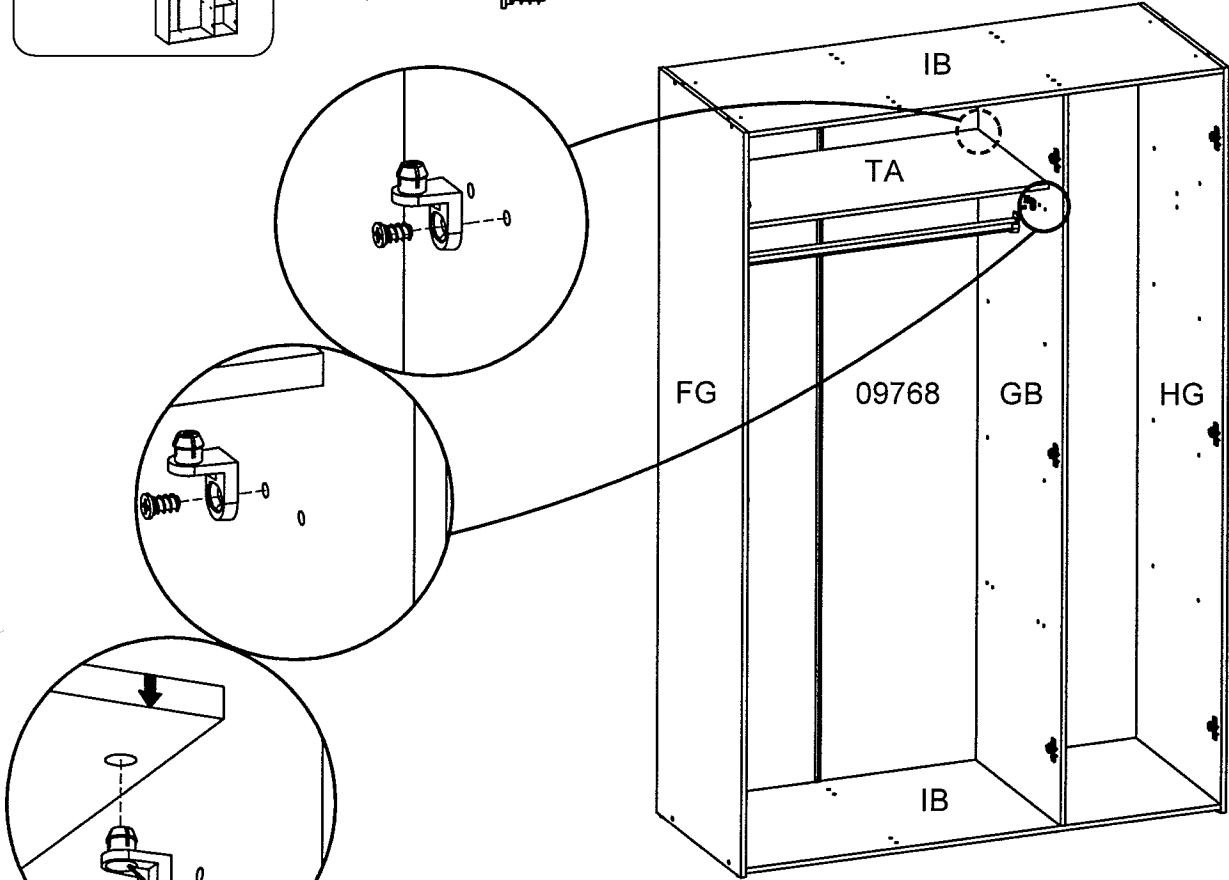

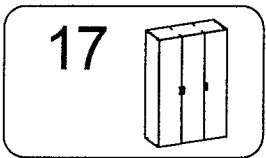
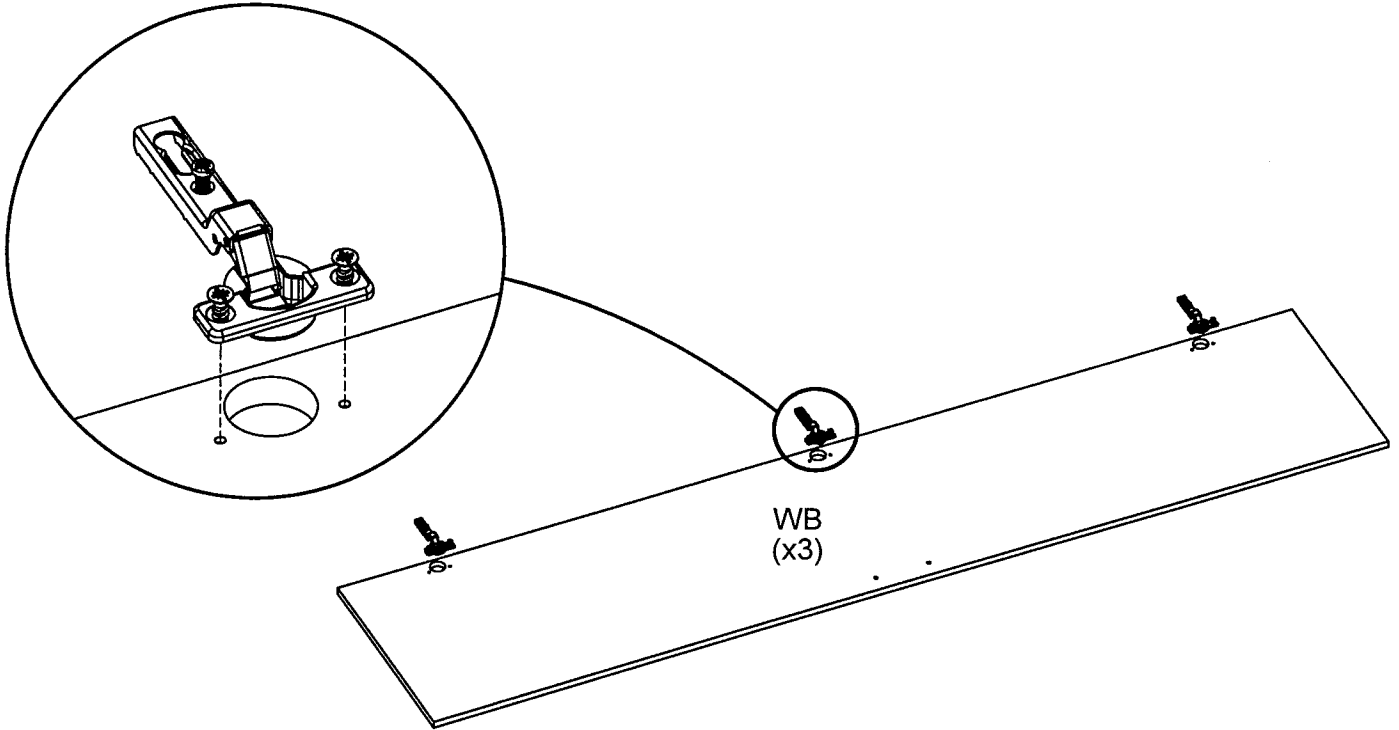
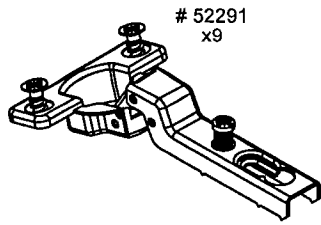
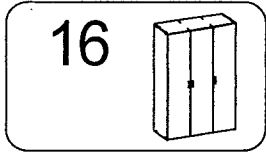

96203
x6

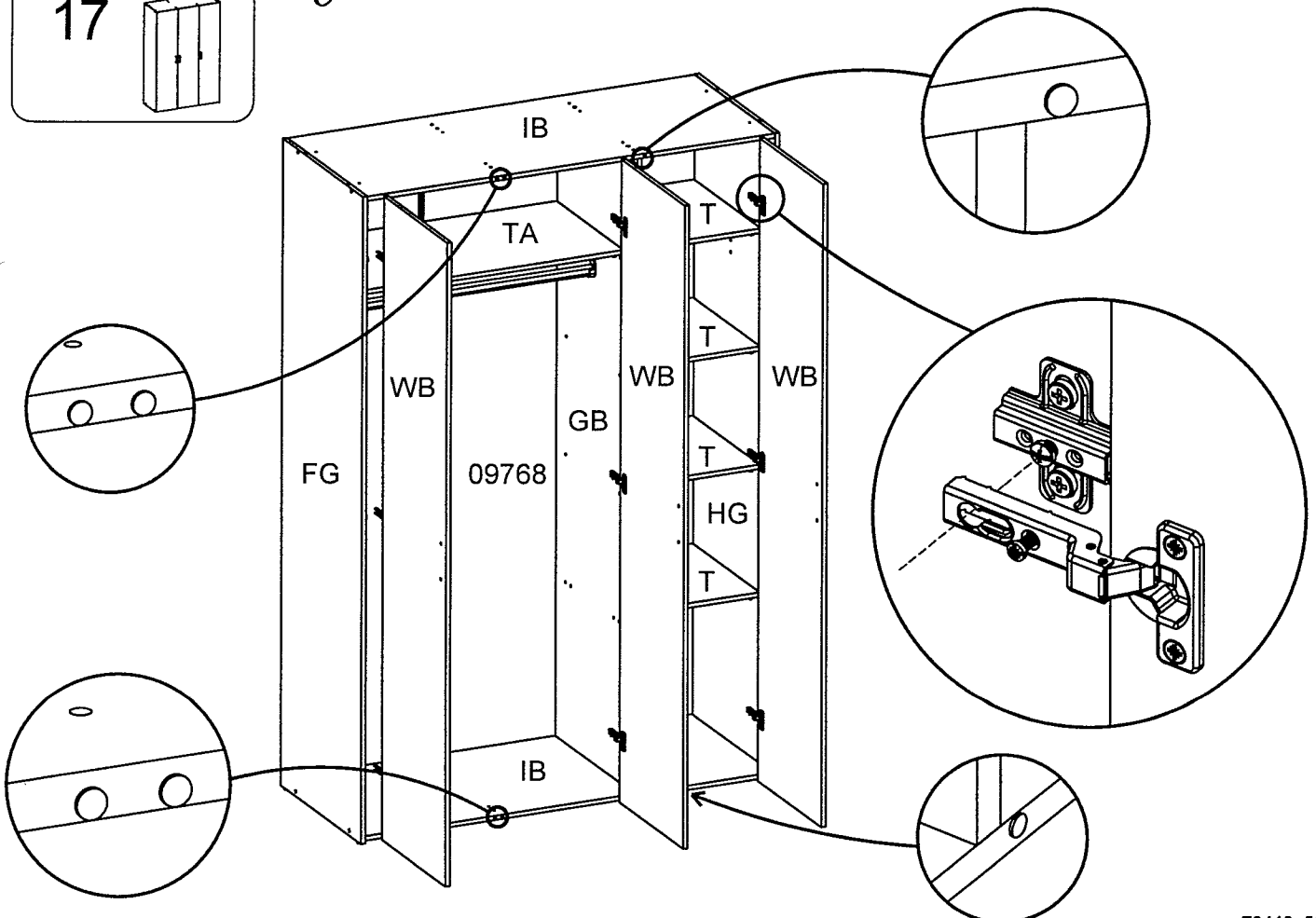

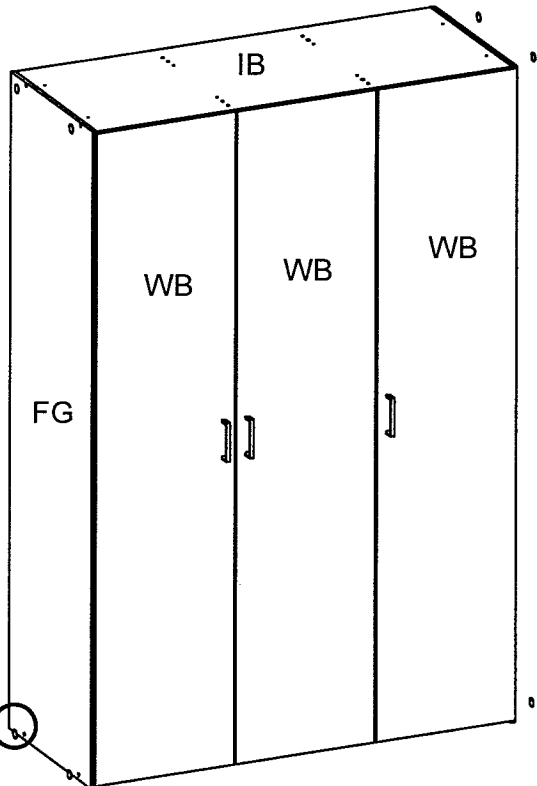
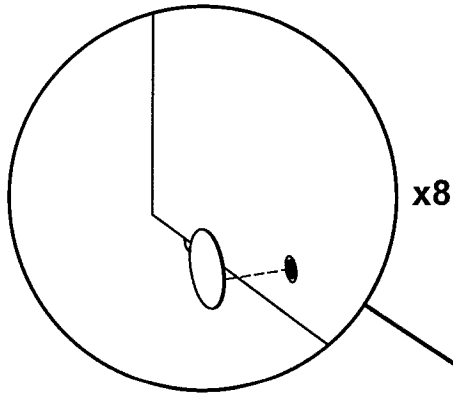
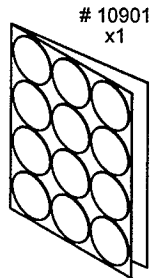
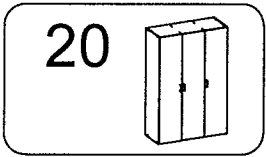
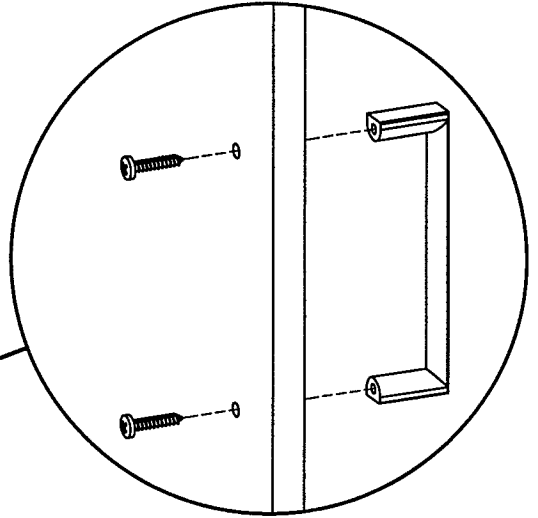
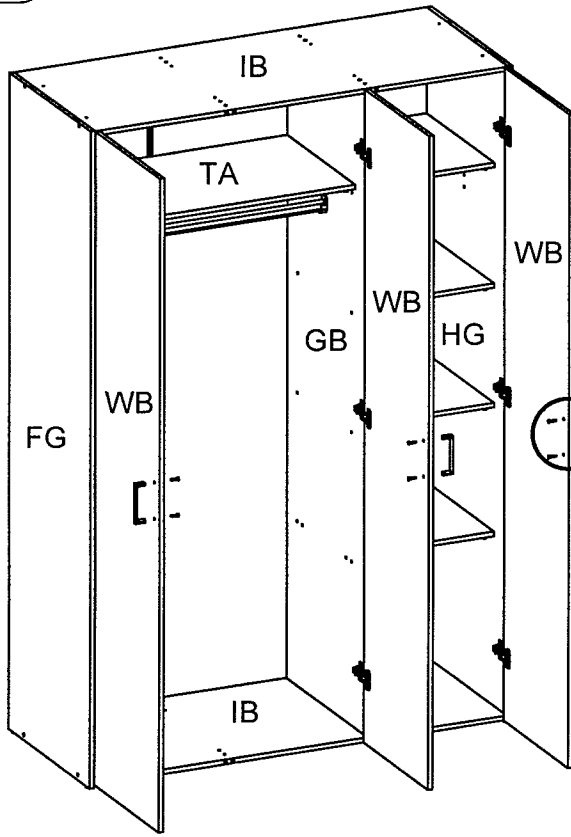
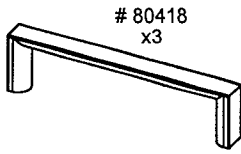
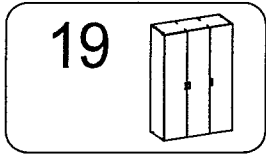

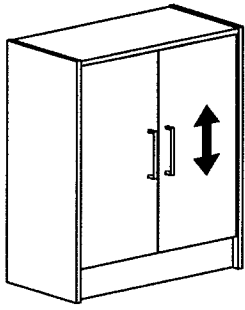

1.

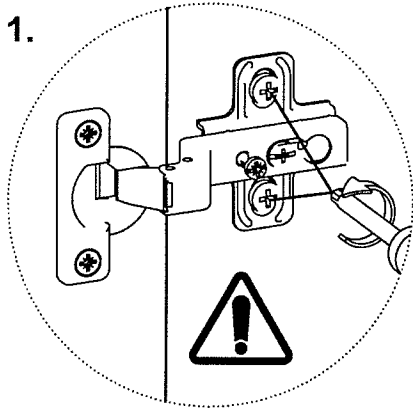

2.

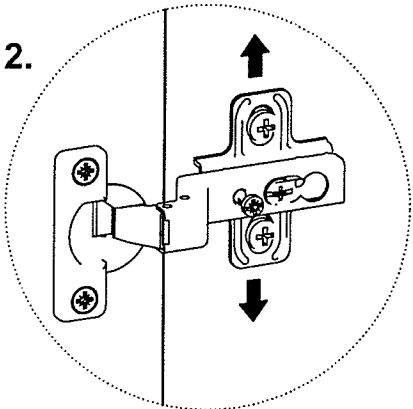

3.

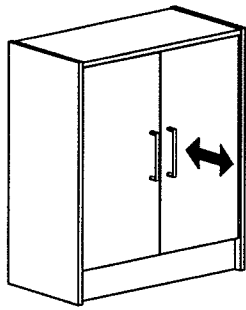
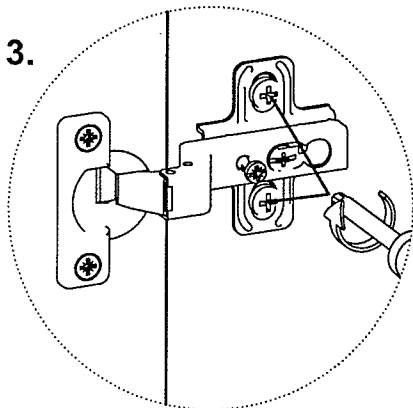

1.

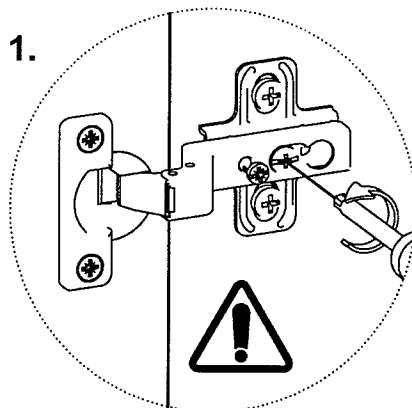

2.

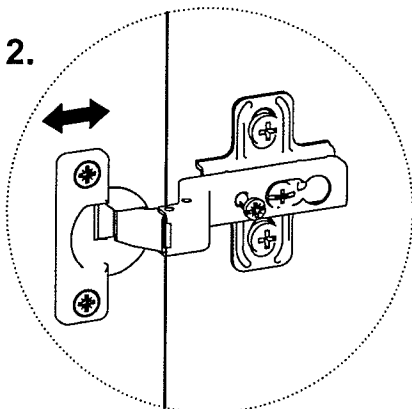

3.

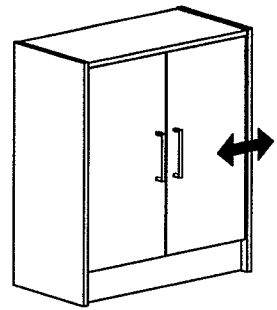
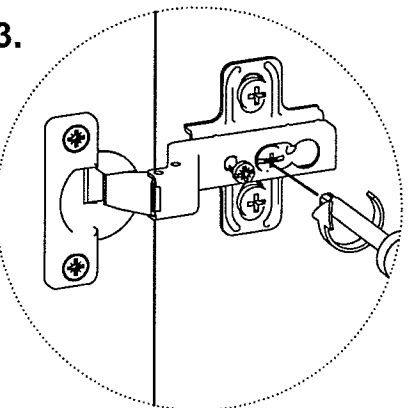

1.

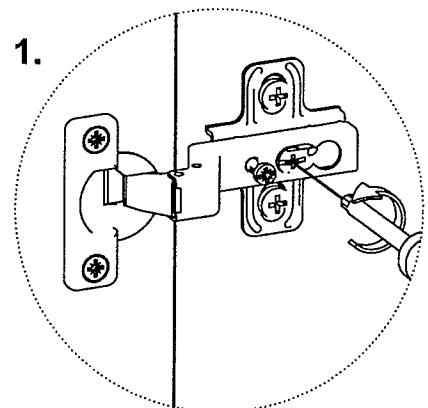

2.

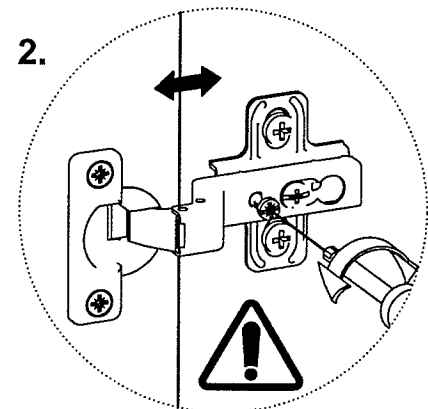

3.

